

# BATTLEFIELD



# THE RENTAL STORE

## (P.A.M.) POSITIONER-ACTUATOR-MANIPULATOR MORE PRODUCTIVITY + LESS INJURIES

### Features & Specifications

- Mount 15 lbs chipping hammer to 35 lbs rivet buster hydro-demo lances, rock drill and other various tools
- Designed to push the tool against the surface, eliminates dead blow
- Water nozzle for dust control
- Air powered over hydraulic and electric
- 100° swing lock hydraulic knuckle boom
- 4 caster wheels and 2 removable 12" wheels
- 3 outriggers for stability
- Multi-function electronic controls
- Air consumption 50 to 60 CFM @ 90 P.S.I.
- Total weight without tool = 1150 lbs. (525 kg.)
- Frame size 32" X 72" without removable wheels

### Benefits

- Proven production boost 2 to 3 times
- Get fast and consistent production on walls and overhead repair
- Eliminates hammer dead blows, vibration and weight
- Eliminates wear and tear on workers
- Greater job focus and comfort = less fatigue, more productivity
- More flexibility in job costing and better delivery time
- Chipping is no longer a punishment
- Quick return on investment
- Self contained, no harmful emissions
- Easier recruiting, less turnover
- Low maintenance and easily transported



**NEW DEALER - AVAILABLE FOR SALE OR RENTAL**  
Distributed by Battlefield Equipment in Ontario, Manitoba & Newfoundland

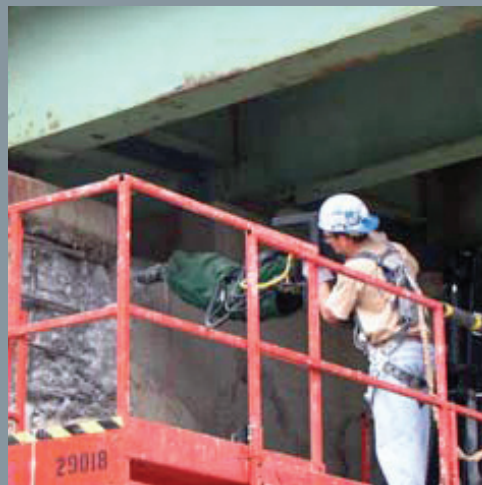

1-800-RENT-CAT | [BattlefieldEquipment.ca](http://BattlefieldEquipment.ca)

**BATTLEFIELD**



**THE  
Rental  
STORE**

# (P.A.M.) POSITIONER-ACTUATOR-MANIPULATOR

## MORE PRODUCTIVITY + LESS INJURIES

### POSITIONING AREA

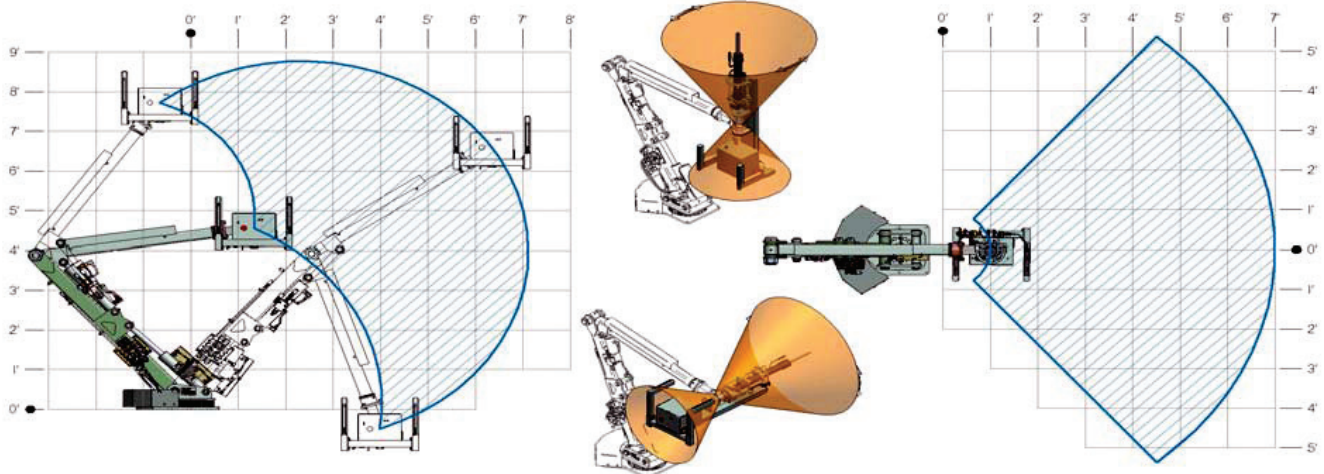

**SEE IT IN ACTION AT [WWW.RNPIND.COM](http://WWW.RNPIND.COM)**

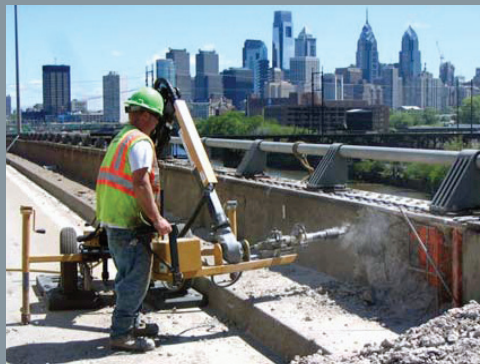

**1-800-RENT-CAT | [BattlefieldEquipment.ca](http://BattlefieldEquipment.ca)**